

SWAC1411

Legend

- 1 Return Air
- 2 Control Pad
- 3 Cold Air Supply
- 4 Power Cord
- 5 1/2" Female water Hose Connector (Inlet/Outlet)
- 6 Condensate Nipple
- 7 Condensate Alarm Jack
- 8 Access Door

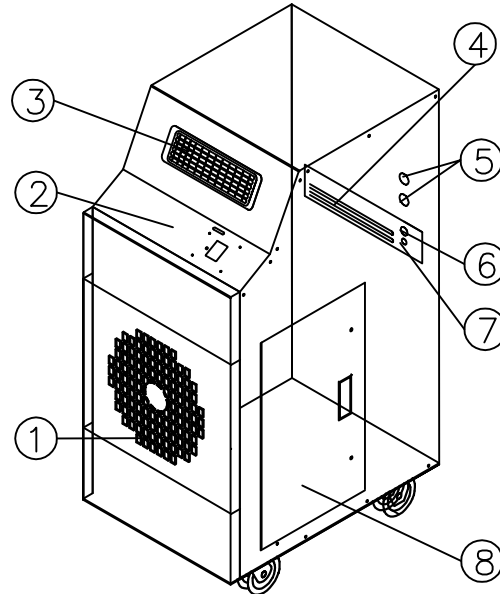

Isometric View

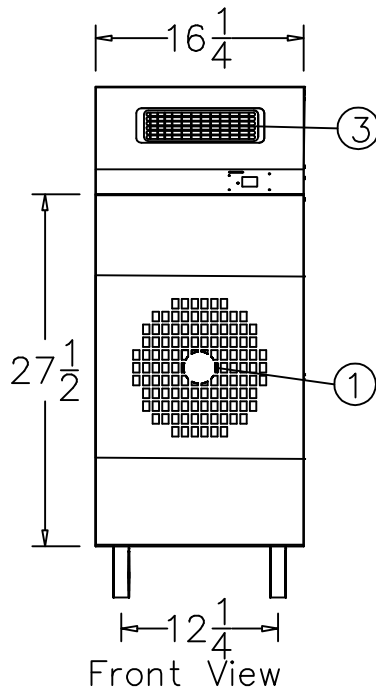

Front View

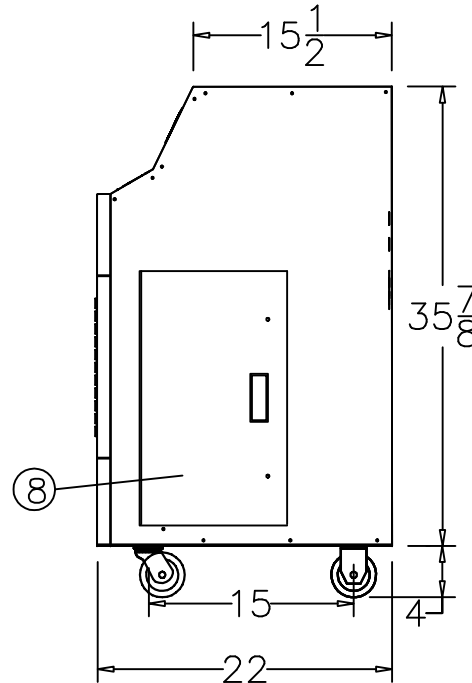

Right View





PENN RADIANT PRODUCTS

1-800-438-2503

SPECIFICATIONS

Model SWAC1411 - 1.1 Ton

COOLING CAPACITY		
	BTU/hr @ 95 F at 60%RH	13,800 (1TON)
COMPRESSOR DATA		
	Compressor Type	MERMETIC ROTARY
	Operating Temperatures	60-110 F .50%RH
	Refrigerant	R-22
FAN DATA		
EVAPORATOR		
	Fan Type (Centrifigul)	BELT DRIVE
	Air Flow (CFM)	450/3
	Supply Air Data	ADJUSTABLE VENT
	Supply Air Chute Data (Optional)	2-5" Dia.x12" Length
	Motor HP	1/3
WATER FLOW DATA		
	Flow Regulation Valve	AUTOMATIC
	Inlet Water 85F-95F Exit(GPM)	3
	Inlet Water 75F-95F Exit(GPM)	1.5
	Inlet Water 65F-95F Exit(GPM)	1
	Inlet Water 55F-95F Exit(GPM)	0.75
ELECTRICAL DATA		
	Power Supply (Volts)	115-1 Phase
	Current Consumption (Amps)	11.25
	Power Consumption (KW)	1.1
	Maximum Circuit Breaker (Amps)	15
	Minimum Circuit Ampacity (Amps)	12.65
	Min/Max Voltage	105-125
	Power Cord Gauge/Length	14AWG/6
	Plug Configruation	NEMA 5-15
DIMENSIONAL DATA		
Unitary Models	Width x Depth x Height (Inches)	16,25X22X40
	Weight (Lbs.)	145
	Shipping Weight (Lbs.)	220
SAFETY DEVICE DATA		
	Compressor Overload	INTERNAL
	Fan Motor Overload	AUTOMATIC INTERNAL
	Evaporator Freeze-up	HOT GAS BYPASS
	High Pressure Switch	MANUAL
	Low Pressure Switch	AUTOMATIC
	Compressor Short Cycle	YES
	Automatic Restart	YES
	Thermostat	MICROPROCESSOR/ DIGITAL
	Condensate Pump w 20' Head Pres.	YES
	Condensate Pump Overflow	YES
	Condensate Tank Overflow	YES

